

ROYALTON R32BHHW HOLDING CABINET



**Royalton Foodservice
Equipment Company**



Royalton Foodservice
Equipment Company

9981 York-Theta Drive, North Royalton, Ohio 44133
440-237-0806 FAX: 440-237-1694 1-800-662-8765

WARRANTY

ROYALTON FOODSERVICE EQUIPMENT COMPANY WARRANTS TO THE ORIGINAL PURCHASER THAT ANY ORIGINAL PART FOUND TO BE DEFECTIVE IN MATERIAL OR WORKMANSHIP WILL BE REPLACED AT OUR DISCRETION WITHIN ONE (1) YEAR FROM DATE OF SHIPMENT.

IF AUTHORIZED BY OUR SERVICE DEPARTMENT, REPLACEMENT PARTS ARE PROVIDED F.O.B. FACTORY. THIS WARRANTY ALSO PROVIDES ONE (1) YEAR LABOR, FROM DATE OF SHIPMENT. END-USER OR RESPONSIBLE PARTY MUST NOTIFY ROYALTON FOOD SERVICE EQUIPMENT CO. FIRST WITH A MODEL AND SERIAL NUMBER AND WHAT TYPE OF PROBLEM IS OCCURRING. AT THAT TIME AUTHORIZATION WILL BE GIVEN AND PARTS WILL BE SENT TO THE END-USER OR SERVICE AGENCY. IF THIS PROCEDURE IS NOT FOLLOWED, END-USER WILL BE RESPONSIBLE FOR SERVICE LABOR & TRAVEL BILL.

OUR TUBULAR HEATERS HAVE A WARRANTY OF FIVE (5) YEARS. WITHOUT PRIOR AUTHORIZATION FROM OUR SERVICE DEPARTMENT, PARTS CANNOT BE RETURNED TO US FOR CREDIT. CREDIT IS SUBJECT TO APPROVAL BY OUR SERVICE DEPARTMENT AFTER INSPECTION OF RETURNED PARTS.

THIS WARRANTY DOES NOT INCLUDE LABOR AND DOES NOT APPLY TO: DAMAGED EQUIPMENT CAUSED BY SHIPPING ACCIDENTS, IMPROPER STORAGE, INADEQUATE MAINTENANCE, NEGLIGENCE, MISAPPLICATION, UNAUTHORIZED ALTERATIONS, LOSSES OR DAMAGES RESULTING FROM MALFUNCTIONS, INCLUDING LOSS OF PRODUCT, IMPROPER INSTALLATION - NO FRYERS, BROILERS, COOK TOPS, OR ANY KIND OF HEAT SOURCE SHOULD BE PLACED ON THE RIGHT SIDE OF THE EQUIPMENT. GLASS, LIGHT BULBS, DOOR AND BODY GASKETS, AND MEAT PROBES ARE NOT COVERED UNDER OUR WARRANTY.

THIS WARRANTY IS IN LIEU OF ALL WARRANTIES EXPRESSED OR IMPLIED.

FOR WARRANTY SERVICE, PLEASE CONTACT CUSTOMER SERVICE AT ROYALTON FOODSERVICE EQUIPMENT COMPANY @ 800-662-8765



Royalton Foodservice Equipment Company

9981 York-Theta Drive, North Royalton, Ohio 44133
440-237-0806 FAX: 440-237-1694 1-800-662-8765

CARE AND CLEANING

The unit should be wiped down, inside and out, after each use. The control module should be checked for dust, grime, or grease around the vent louvers and wiped on a regular basis. Because the roasting is done at low temperatures, there is very little grease build-up. Over time, however, grease will begin to stick to the walls and floor of the unit. Hot soapy water with a non-abrasive pad or oven cleaner for stainless steel is best for cleaning the interior. For the exterior, we recommend hot soapy water with a non-abrasive pad, or stainless steel cleaner and polish. Always wipe with the grain. Failure to remove greasy build-up can cause bacterial growth within the oven cavity. It can also impair the accuracy of the temperature sensors that keep the heat cycling properly.

- **DO NOT** use a pressure washer or water under pressure. Avoid getting water inside the control module, because it ruins the electrical components and **VOIDS THE WARRANTY**.
- **NEVER** locate your Royalton unit next to grease emitting equipment such as deep fryers or griddles.
- **DO NOT** block louvers or cooling fans in the control module. Doing so will cause the unit to overheat and shut down the oven.

CLEANING PROCEDURE

1. Press power switch off
2. Unplug power cord.
3. Remove interior parts for cleaning (side racks, pan slides, drip pan).
4. Clean interior and exterior.
5. Replace interior parts.
6. Plug in power cord.

INSTALLATION

LEVELING THE OVEN

To level the oven, screw the leg feet in or out.

1. Screw the adjustable feet all the way into the leg. Check that the oven is level on the front, back and sides; if not adjust accordingly.
2. After leveling, the distance from the underside of the oven to the floor should be close to 7-3/16" (18.3 cm).

Note: This measurement is important for docking alignment of transport cart.

ALIGNING THE DOCKING MECHANISM

1. Open the oven door fully.
2. Move and latch the transport cart into place at the front of the oven. The two alignment pins on the front of the cart should line up with the channeled openings in the docking assembly. The locking bar must lock to the docking assembly. This adjustment can be made by moving the docking assembly in or out until the locking bar is fully engaged onto docking assembly. Tighten four bolts with wrench.
3. Align the inner vertical edge of the tracks on the transport cart with the same vertical edge of the tracks located on the oven floor. This adjustment can be made by moving the vertical tracks on the oven floor either left or right. Tighten the six bolts with a wrench.
4. Level the tracks on the transport cart to the same height as the tracks on the oven floor. This adjustment is made by rising or lowering the nuts on the six leveling screws located (3X) on each side of the transport cart.
5. When the transport cart locks properly to the front of the oven, the unit is ready for loading operation.

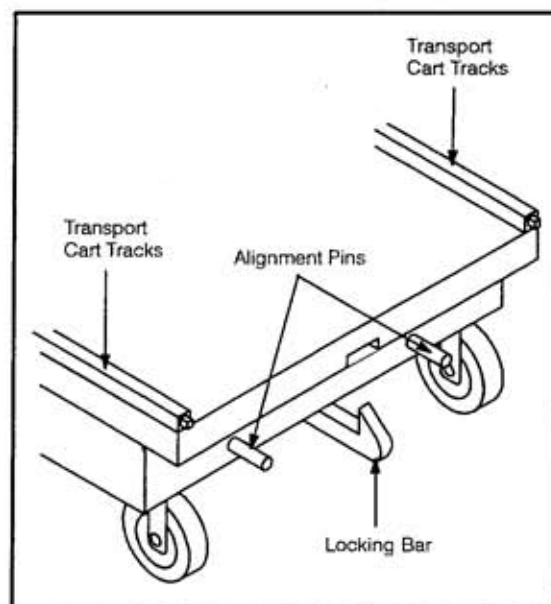

USING THE TRANSPORT CART

When loading the oven with the transport cart, be sure the cart is securely locked to the oven before transferring the load. To move the load into the oven, step down on the upper foot pedal and push the product forward. The roll-in basket dolly should be inserted all the way into the oven before removing the transport cart. This prevents the load from spilling and allows the door to close properly. To remove the transport cart from the oven, step down on the lower foot pedal and pull the cart away from the oven. Close the door.

While unloading the oven, the transport cart must be securely locked to the front before transferring the load. The load is pulled from the oven onto the cart.

WARNING!!

Be sure the roll-in basket dolly is locked securely on the transport cart before releasing the cart from the oven.

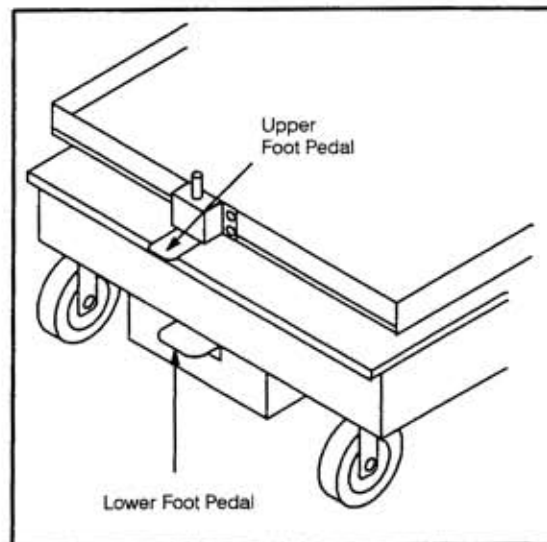

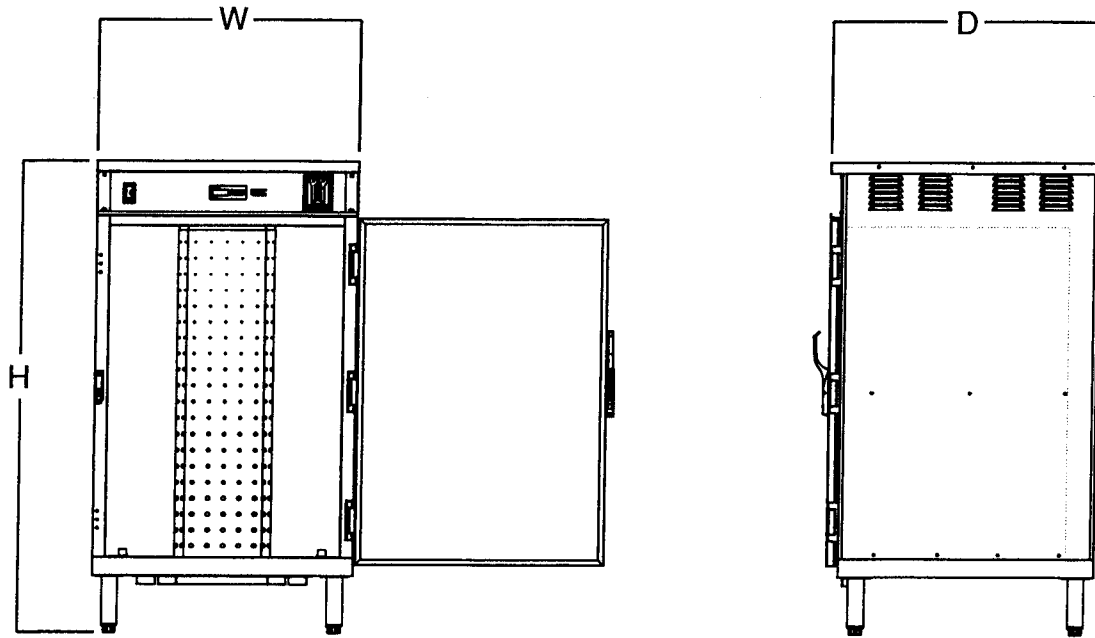

Model Number	13x26x2 ⁵ / ₈ Basket	Height (H)	Depth (D)	Width (W)	Shipping Wt. (lbs)	Volts	Total Watts	Total Amps	Hertz/Phase	Power Cord Plug (NEMA)
	MAX									
R32BHHW	32	59"	33 ³ / ₁₆	33 ¹ / ₄ "	446	120	1900	16	60 1Ø	5-20P 

Bidding Specifications

Royalton Model # R32BHHW, gentle convection holding cabinet (companion unit for R32BRTO) with optional roll in cart and dolly, accomodates up to 32 wire baskets (13"x26"x2-5/8"). Food capacity 320-14oz single serving containers, 280# max, fully insulated, stainless steel construction

NOTE: Cart, dolly, and baskets sold seperately.



**Royalton Foodservice
Equipment Company**

9981 York-Theta Drive, North Royalton, Ohio 44133
440-237-0806 FAX: 440-237-1694 1-800-662-8765

OPERATING INSTRUCTIONS FOR 3-BUTTON CONTROLLER

- 1.) POWER SWITCH ON
- 2.) HOLD SET TEMP WHILE ADJUSTING TEMP \triangle ∇
- 3.) CABINET WILL MAINTAIN SET TEMPERATURE, UNLESS TEMPERATURE IS CHANGED.

NOTE: Pertains to models RSH or SSRSH and RHP or SSRPH and RHHR or SSRHHR

CAUTION: Risk of fire and electric shock. Replace only with manufacturer's cord set, part # - See part's breakdown.

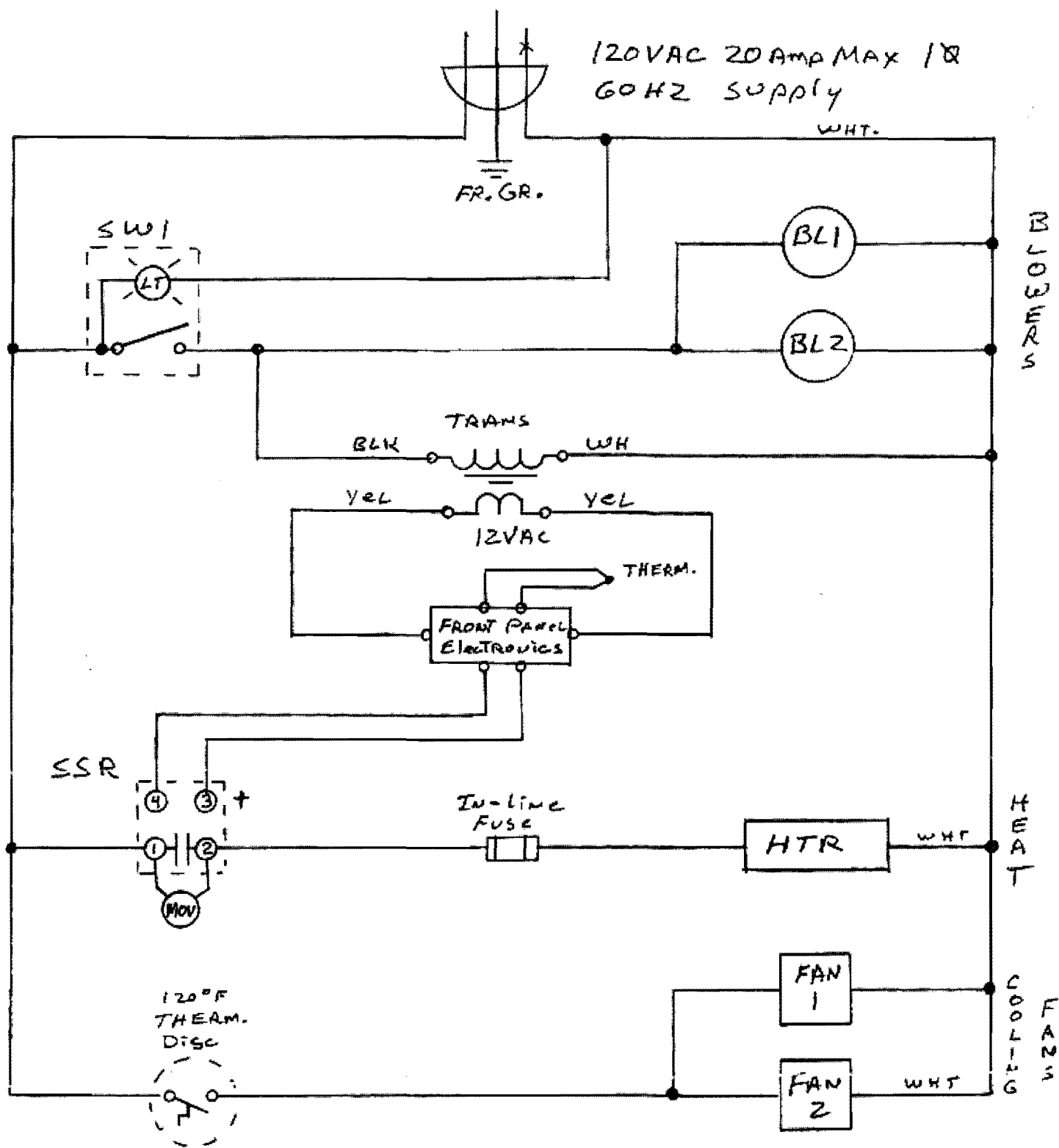

R32 BHHW

HOLDING CABINET

7-17-08
DLK

ROYALTON FOODSERVICE EQUIPMENT COMPANY PARTS LIST

PART#	DESCRIPTION	VOLTS	MODEL SERIES
223	R/C NETWORK - SURGE PROTECTION	120	RHHC, RHHR, RHHP-VT RHHT, RPC-US
278	CONTACTOR - ASK COIL VOLTAGE	208-240	RRH
284	ROAST KNOB		RRH, SS2RRH
288	R/C NETWORK - SURGE PROTECTION	208-240	RRH
289	BLUE TIMER KNOB		RRH
670	HEAVY DUTY PLUG 30 AMP OR 50 AMP	208-240	RRH, SS1 & SS2RRH
761	FUSE	208-240	RRH, SS1 & SS2RRH
917	MEAT PROBE JACK		SS2RRH
967	FUSE HOLDER	208-240	RRH, SS1 & SS2RRH
923	THERMOSTAT KNOB		RHH, RSH, RCS
955	BASE RECEPTACLE	120	RSH
965	HEAT FUSE KIT	120	RHH
966	HEAT FUSE KIT	208-240	RRH
968	BLOWER MOTOR ASSEMBLY KIT	208-240	RRH
968A	BLOWER MOTOR ASSEMBLY KIT (NO PLUGS)	208-240	SS1 & SS2 RRH
969	BLOWER MOTOR ASSEMBLY KIT	120	RHH
969A	BLOWER MOTOR ASSEMBLY KIT (NO PLUGS)	120	SSRHH, SSRHP-US
970	GASKET TOP BODY KIT (STRIP & STICK)		RRH, RHH
972	GASKET DOOR		C1 BODY
973	GASKET DOOR		C2 BODY
974	GASKET DOOR	PER DOOR	C4 BODY
993	GASKET DOOR	PER DOOR	C4US BODY
994	GASKET DOOR	PER DOOR	C4W BODY
975	GASKET DOOR		RSH-1206
976	GASKET DOOR		RSH-1209
977	GASKET DOOR		RSH-1806
978	GASKET DOOR		RSH-1809
980	HINGE FOR DOOR		ALL MODELS
1869	GASKET DOOR		RSH-1205
1637	GASKET DOOR		RSH-2106
1641	GASKET DOOR		RSH-2104
1644	GASKET DOOR	ONE DOOR	C3 BODY
2382	GASKET DOOR	ONE DOOR	RHP-US, RPC-US
1035	CASTER 3-1/2" SWIVEL		RSH
1036	CASTER 3-1/2" SWIVEL w/BRAKE		RSH
1037	CASTER 5" SWIVEL		RHH,RRH,SS1&SS2 RRH,RSH
1038	CASTER 5" SWIVEL w/BRAKE		RHH,RRH,SS1&SS2 RRH,RSH
1888	CASTER 6" SWIVEL		SSRHP-VT-CAUS

1887	CASTER 6" SWIVEL W/BRAKE			SSRHP-VT-C4US	
62	COOLING FAN		120	RRH, SS1 & SS2RRH, SSRHP-VT-C4US	
1039	COOLING FAN		208-240	RRH, SS1 & SS2RRH,	
1040	HEAT ELEMENT 2600W (SPECIFY 220V OR 240V)		208-240	RRH, SS1 & SS2RRH,	
1043	HEAT ELEMENT 1900W (SPECIFY 220V OR 240V)		208-240	RRH, SS1 & SS2RRH,	
1044	HEAT ELEMENT 1000W		120	RHH C1 & C2	
1045	HEAT ELEMENT 1800W		120	RHH C3, C3US, C3W RHH C4, C4US, C4W	
979	HEATER STRIP 400W		120	RSH, SSRSH, RCS	
1296	HEATER STRIP 150W		120	SSRSH, RSH	
1645	HEATER STRIP 700W		120	RHP	
1646	HEATER STRIP 800W		120	RHP	
1686	HEATER STRIP 500W		120	SSRHP, SSRSH, SS1 & SS2RRH	
1687	HEATER STRIP 500W		208-240	SS1RRH, SS2RRH	
1041	CORD GRIP		208-240	RRH, SS1 & SS2RRH,	
1042	CORD GRIP		120	RHH	
1046	LATCH MAGNETIC/MECHANICAL w/LOCK			ALL MODELS	
1047	LATCH MAGNETIC/MECHANICAL w/o LOCK			ALL MODELS	
668	STRIKE PLATE FOR ABOVE LATCH ASSEMBLY			ALL MODELS	
1048	PILOT LIGHT - AMBER (ROAST/HOLD)		208-240	RRH	
1049	PILOT LIGHT - RED (HEAT)		120, 208-240	RRH, RHH, RSH	
1050	POWER CORD w/PLUG - 15 AMP		120	RHH 1000W TOPS	
1051	POWER CORD w/PLUG - 20 AMP		120	RHH 2000W TOPS	
1052	POWER CORD w/PLUG - 50 AMP		208-240	RRH 6100W TOPS	
1053	POWER CORD w/PLUG - 30 AMP		208-240	RRH 4100W TOPS	
1054	POWER CORD SET COMPLETE - 15 AMP		120	RSH, SSRSH, RHP, SSRHP, RHHR, SSRHHR	
1055	SWITCH, ON-OFF		120, 208-240	RRH, RHH, RSH, RHP, RSW, RCS	
1056	SWITCH FOR ROAST TIMER		208-240	RRH	
1057	TEMPERATURE PROBE 350 DEG.		208-240	RRH	
1057A	TEMPERATURE PROBE 350 DEG.		208-240	SS1 & SS2 RRH	
1058	THERMOMETER			RHH, RSH	
1059	THERMO-SWITCH FOR COOLING FANS		120, 208-240	RHHP-VT, RRH, SS1&SS2RRH	
1060	THERMOSTAT		120	RHH, RSH, RCS, RHP	
1061	THERMOSTAT (TEMPERATURE CONTROL BOARD)		120, 208-240	RRH	
	350 DEG. ROAST, 250 DEG. HOLD w/POTENTIOMETERS				
1062	TERMINAL BLOCK 3-POLE		208-240	RRH, SS1RRH, SS2RRH	
1063	TERMINAL BLOCK 6-POLE		120, 208-240	RHH, RRH, SS1 & SS2RRH	
1064	TIMER		208-240	RRH	
1151	1" LEG w/RUBBER BOOT				
1166	4" LEG				
1188	CAM w/SCREW				

1357	SS1 OVEN CONTROLLER (CPU BOARD)	208-240	SS1RRH	
1358	SS1 OVEN CONTROLLER (DISPLAY BOARD)	208-240	SS1RRH	
1363	M.O.V.	120, 208-240	SS1RRH, SS2RRH, SSRHH SSRHP, SSRSH, SSRHHP-VT'S	
1378	50-AMP SOLID STATE RELAY w/M.O.V.	120, 208-240	ALL MODELS	
1379	25-AMP SOLID STATE RELAY w/M.O.V.	120, 208-240	SS1RRH, SS2RRH	
1387	SNAP SWITCH - O.T. DEVICE	208-240	SS1RRH, SS2RRH	
1389	TRANSFORMER (240-12)	208-240	SS1RRH, SS2RRH	
1394	MEAT PROBE		SS1RRH, SS2RRH	
1501	12 POLE TERMINAL BLOCK	208-240	SS1RRH, SS2RRH	
1595	TEMP PROBE RTD 2K	120	SSRHH, SSRHP, SSRSH SSRHHP-VT, SSRPC	
1601	SS ELECTRONIC CONTROLLER AIR	120	SSRHH, SSRHP, SSRSH SSRHHP, SSRPC	
1601A	AIR TEMPERATURE CONTROL BOARD	120	SSRHH-VT, SSRHP-US	
1601B	WATER TEMPERATURE CONTROL BOARD	120	SSRHH-VT, SSRHP-US	
1602	TRANSFORMER (120-12)	120	SSRHH, SSRHP, SSRSH SSRHHP, SSRPC	
1607	SWITCH - SPST ROCKER	208-240	SS2RRH	
1626	SS2 ELECTRONIC CONTROLLER	208-240	SS2RRH	
1632	POWER CORD w/PLUG, 8/3, 50 AMP	208-240	SS1RRH, SS2RRH - 8100W RRH-8100W	
1639	30-AMP O.T. DEVICE	208-240	SS1RRH, SS2RRH 4100W & 6100W	
1640	HEAT FUSE KIT 40 AMP O.T. DEVICE	208-240	SS1RRH, SS2RRH - 8100W	
1661	LATCH MAGNETIC/MECHANICAL w/LOCK INSULATED HANDLE		SS1RRH, SS2RRH, RRH	
1691	DOOR VENT KNOB		RRH, RHH, RSH	
1694	POWER CORD SET COMPLETE - 20 AMP	120	RHP, SSRHP, RHHR, SSRHHR 2000W	
1695	BASE RECEPTACLE - 20 AMP	120	SSRHP	
1696	LAMP-250W, 120V	120	RCS	
1702	POWER CORD w/PLUG, 14/3, 5-15, 72" LONG	120	RCS, RSW	
1731	BULBS		RSW	
1742	HEAT ELEMENT - TUBULAR (AIR) 1000W	120	SSRHH-VT-C2US	
1743	HEAT ELEMENT (HAIRPIN) 250W	120	RSW	
1744	HEAT ELEMENT (STRAIGHT) 250W	120	RSW	
1745	SNAP BUSHING		RSW	
1746	CORD GRIP		RSW	
1747	KNOB-BLACK		RSW	
1748	CAP FOR KNOB-BLACK WITH WHITE INDICATOR		RSW	
1749	Thermostat	120	RSW	
1750	PORCELAIN SNAP IN SOCKET WITH 8" LEADS	120	RSW	

1751	HEATER BRACKET GUARD			RSW	
1752	1/8" CLEAR TEMPERED GLASS 13-3/4"WX20-1/4"H		FOR 30" & 40"	RSW	
1753	ALUMINIUM FOIL TAPE 2"WX60 YARDS LONG			RSW	
	3 MIL BACKING				
1754	WIRE NUT - YELLOW			RSW	
1755	WIRE NUT - BLUE			RSW	
1756	WIRE NUT - ORANGE			RSW	
1757	SCREW 10/32X3/8" SELF TAPPING SS410-			RSW, RSH-1205	
	PHILLIPS TRUSS HEAD				
1758	SCREW 10/32X3/8" SELF TAPPING SS410-			RSW, RSH-1205	
	PHILLIPS PAN HEAD				
1759	SCREW 8/32X3/8" SELF TAPPING SS410-			RSW, RSH-1205	
	PHILLIPS TRUSS HEAD				
1760	LEVITON PORCELAIN LAMP HOLDER - MEDIUM		120	RCS-1800 OR 2600	
	BASE, KEYLESS 660W, 250V			SERIES	
1761	CORD GRIP 1/2" NPT (CABLE DIA .24" TO .47")			RCS-1800 OR 2600 SERIES	
1762	CUTTING BOARD - 18X24X1/2			RCS-1800 OR 2600	
				SERIES	
1763	GOOSENECK CHROME PLATED 9"X.585 1/8X1/8M			RCS-1800 OR 2600	
				SERIES	
1764	RELAY 275F, 120V AC, DPDT 30A		120	RHH-VT-C2US/C4US	
				SSRHHP, SSRPC	
1765	PROBE-WATER BATH, RTD2K 22"LONG SS9'LEADS		Original	RHH-VT-C2US/C4US	
1765A	PROBE-WATER BATH, RTD2K-NEW UNIT w/SUMP			RHH-VT-C2US/C4US	
				SSRHHP, SSRPC	
1766	HEAT ELEMENT 1800W, 120V TUBULAR (AIR)		120	RHH-VT-C4US, SSRHHP, SSRPC	
1767	HEAT ELEMENT 1800W, 120V TUBULAR (WATER)		120	RHH-VT-C3US, C4US, SSRHHP	
	NEW UNIT w/SUMP				
1767A	HEAT ELEMENT 1800W, 120V TUBULAR (WATER)		120	RHH-VT-C4US	
	ORIGINAL (S.S. WATER PAN SITS ON FLOOR)				
1768	HEAT ELEMENT 1000W, 120V TUBULAR (WATER)		120	RHH-VT-C1US, C2US, SSRHHP	
830	DECAL - ROYALTON COOK/HOLD STANDARD			RRH	
831	DECAL - ROYALTON COOK/HOLD US			RRH	
832	DECAL - ROYALTON COOK/HOLD WIDE			RRH	
833	DECAL - ROYALTON HEAT/HOLD STANDARD			RHH	
834	DECAL - ROYALTON HEAT/HOLD US			RHH	
835	DECAL - ROYALTON HEAT/HOLD WIDE			RHH	
839	DECAL - ROYALTON SATELLITE			RSH-1200 SERIES -	
				1205, 1206, 1208, 1209	
840	DECAL - ROYALTON SATELLITE			RSH-1806, 1809	
1094	DECAL - ROYALTON SATELLITE			RSH-2104, 2106	
1310	DECAL - ROYALTON DIGITAL COOK/HOLD			SS1	
1592	DECAL - ROYALTON KNOB COOK/HOLD			SS2	

1593	DECAL - ROYALTON DIGITAL SATELLITE			SSRSH	
1594	DECAL - ROYALTON DIGITAL HEAT/HOLD			SSRHH, SSRHP	
1673	DECAL - ROYALTON SHELF WARMER			RSW-30-2	
1676	DECAL - ROYALTON CARVING STATION			RCS-1800-2	
1727	DECAL - ROYALTON DUAL DIGITAL (HUMIDITY)			SSRHH-VT	
1885	HINGE COVER ONLY			ALL MODELS	
1889	GASKET DOOR			RSH-1208	
1890	GASKET DOOR		PER DOOR	C-3	
1891	GASKET DOOR			C1US	
1892	GASKET DOOR			C2US	
1893	GASKET DOOR			C3US	
1895	GASKET DOOR		PER DOOR	C1W	
1896	GASKET DOOR			C2W	
1897	GASKET DOOR		PER DOOR	C3W	
1898	GASKET DOOR			RSH-2109	
1901	GASKET DOOR			RSH-1808	
2054	LATCH MAGNETIC (OFFSET HANDLE) INSULATED			SS1RRH, SS2RRH, RRH	
2216	GASKET DOOR (DUTCH DOORS)		PER DOOR	SSRHP-US, SSRPC-US	
2217	GASKET DOOR (SINGLE DOOR)			SSRHP-US, SSRPC-US	
2265	POWER CORD SET COMPLETE - 30 AMP (CANADA)		120	RHP, SSRHP, RHHR, SSRHHR	
				2000W	
2266	POWER CORD SET COMPLETE - 15 AMP		240	RSH, SSRSH, RHP, SSRHP,	
				RHHR, SSRHHR UP TO 2000W	
2170	ABB TCSHAA MOTOR SENSING RELAY			R32BRTO-R14BRTO	
2174	AG-8 FUSE			R32BRTO	
2183	HEATING ELEMENT, 10,000 WATTS		208	R32BRTO	
2406	SPRING STEEL FOR DOOR GASKET-1 SET, 4 PCS.			R32BRTO	
1360	3-POLE CONTACTOR - ASK COIL VOLTAGE		208-240	SS1, SS2 RRH, SS2 RCRH	
460	R/C NETWORK - SURGE PROTECTION		208-240	RRH	
	C4 GLASS				
1929	DECAL ROYALTON PROFFER 7.312" X 21.50"		120	SSRHP-US/SSRPC-US	
2458	GASKET DOOR (LOW PROFILE)			R32BHHW	
2411	LATCH TOTAL MAGNETIC		STRIKE PLATE 7.80		
2403	CONTACTOR 3 POLE		208-240	RCRH-8135-C1US	
*** ALL STAINLESS CABINET PARTS (INTERNAL & EXTERNAL) WILL BE SOLD FROM ROYALTON FOODSERVICE.					
*** ALL STAINLESS TOP MODULE PARTS (INTERNAL & EXTERNAL) WILL BE SOLD FROM ROYALTON FOODSERVICE.					